



### Key Features

- IP-to-sync converter function
- **Embedded** – STANAG 5066 ARQ Server, JITC certified, Edition 3 compliant
- **Embedded** – IP & COSS Clients
- **Embedded** – STANAG 4538 Proxy \*
- **Embedded** – RTAWC low-rate Vocoder\*
- **Email, Chat & Messaging** – via SIS Protocol
- **Deployment** – ship-borne & shore station
- **Operation** – Point-to-point and Broadcast
- **Data Modems** – SSB, ISB & WBHF
- **ALE** – 2G & 3G with ALM
- **Menu-Driven control & configuration**
- **DTE port** – Synchronous / Asynchronous
- **Ethernet LAN interfaces** – for Control and IP-based Data services
- **Asynchronous Serial Port** – for ACP-127
- **Factory Presets** – lower integration effort

\* Note: Future option

### Data and Voice Interfaces

The RC8 features serial and Ethernet interfaces for data and external GPS and two audio interfaces.

Various external RapidM or third party clients can bind with the 5066 server or the 4538 Proxy thus allowing multiple applications to concurrent access to the 'radio line' - ARQ Server / Encryptor / Modem / Transceiver. A *synchronous balanced DCE port* is built into the RC8 unit to interface with a bulk encryption (COMSEC) unit.

### RC8 Product Overview

The RC8 ARQ Server & IP Controller is a purpose-built platform for Automatic Repeat reQuest (ARQ) and Vocoder functions used in maritime and strategic long-range (BLOS) communications systems.

In conjunction with the RM8 Software Defined Modem (SDM) and external link encryptor, the RC8 provides robust, secure voice, data and position communication capability over HF links even in severely degraded channels conditions. This fully integrated, qualified system ensures optimal performance and functionality and offers peace-of-mind stemming from RapidM's commitment to long-term product availability and support.

Services include voice, position transfer, Email, messaging, ACP 127 chat and IP data transfer.

### Description

The RC8 is designed for 19-inch rack installations with all standard interfaces necessary for maritime shore and ship-borne installations.

In its most basic configuration, the RC8 provides a 'IP-to-sync' data converter function. The RC8 is capable of hosting a STANAG 5066 ARQ server for error-free data transfer. The STANAG 5066 IP and COSS Clients are embedded in the RC8. Alternatively the RC8 can host a STANAG 4538 Proxy for secure data transfer using the STANAG 4538 xDL modes provided in the RM8.

Additionally, the RC8 will run RapidM's RTAWC a low-rate Vocoder designed for HF channel conditions.

The RC8 can be used in Fixed Frequency or Multi Frequency networks. For the latter ALE 2G or 3G (Fast Link Setup) channel access function is utilized for link establishment and link maintenance.

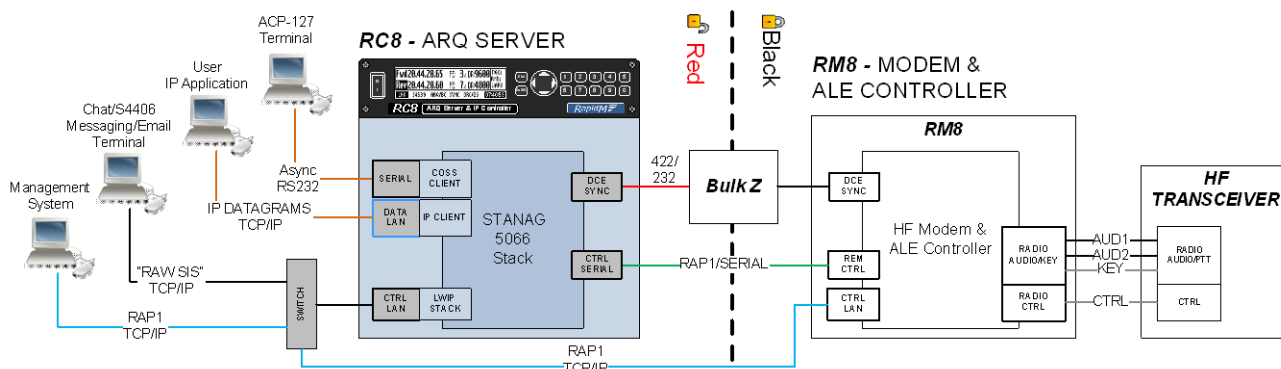

| STANAG 5066 ARQ                |  |
|--------------------------------|--|
| <b>MODES</b>                   | <ul style="list-style-type: none"> <li>ARQ, non-ARQ (Broadcast) &amp; EMCON (Emission Control) Modes</li> </ul>  |
| <b>CLIENTS</b>                 | <ul style="list-style-type: none"> <li>Embedded STANAG 5066 COSS (for ACP-127 Messaging) and IP Clients</li> <li>Compatible with STANAG 5066 CFTP, HMTP, HFPOP and COSS Clients</li> <li>Compatible with POP3 &amp; SMTP Servers (Email) – SMTP, RFC 2821, Outlook Email</li> </ul>  |
| <b>FEATURES</b>                | <ul style="list-style-type: none"> <li>Non-ARQ Data Transfer: Data is sent out, without any form of acknowledgement. Used for broadcasting and for sending data to single stations in EMCON.</li> <li>ARQ Data Transfer: Used for sending data to a single radio that is not in EMCON mode.</li> <li>SIS Protocol: The RC8 STANAG 5066 server supports the RAW SIS protocol via TCP/IP.</li> <li>Multiplexing: The RC8 enables multiple applications to simultaneously send/receive data.</li> <li>Data Priority: Each unit data has a priority value. Higher precedence data is sent first.</li> <li>Collision avoidance and recovery: The RC8 provides a listen-before-transmit function.</li> <li>Data Rate Change (DRC): The RC8 adjusts the transmitter data rate automatically.</li> <li>Fixed Frequency network or Multi Frequency network support.</li> <li>Interoperability: Other STANAG 5066 products, e.g. RC66, BFEM66, 4KMA, RFIAN.</li> </ul> |
| STANAG 4538 PROXY*             |  |
| <b>MODES</b>                   | <ul style="list-style-type: none"> <li>ARQ, non-ARQ (Broadcast) &amp; EMCON (Emission Control) Modes</li> </ul>  |
| <b>CLIENTS</b>                 | <ul style="list-style-type: none"> <li>Embedded STANAG 5066 COSS (for ACP-127 Messaging) and IP Clients</li> <li>Compatible with STANAG 5066 CFTP, HMTP, HFPOP and COSS Clients</li> <li>Compatible with POP3 &amp; SMTP Servers (Email) – SMTP, RFC 2821, Outlook Email</li> </ul>  |
| <b>FEATURES</b>                | <ul style="list-style-type: none"> <li>Non-ARQ Data &amp; ARQ Transfer</li> <li>SIS Protocol: The RC8 STANAG 4538 server supports the RAW SIS protocol via TCP/IP</li> </ul>   |
| RAPIDM RTAWC LOW-RATE VOCODER* |  |
| <b>MODES</b>                   | <ul style="list-style-type: none"> <li>Secure digital audio or PLAIN (SSB) analog voice (for interoperability)</li> </ul>  |
| <b>FEATURES</b>                | <ul style="list-style-type: none"> <li>Automatic DRC based on voice quality.</li> <li>Late Entry</li> </ul>  |

\* Note: Future option

| GENERAL SPECIFICATIONS              |  |  |
|-------------------------------------|--|--|
| <b>SIZE &amp; WEIGHT</b>            | <ul style="list-style-type: none"> <li>Width: 212.2 mm</li> <li>Depth: 225.6 mm</li> </ul> | <ul style="list-style-type: none"> <li>Height: 41.1 mm (excl. front panel)</li> <li>Height: 44.1 mm (incl. front panel)</li> <li>Weight: 2.2 kg</li> </ul>                     |
| <b>ENVIRONMENTAL SPECIFICATIONS</b> | Climatic   | <ul style="list-style-type: none"> <li>Storage/Operation: -30 °C to +70 °C (MIL-STD-810F)</li> <li>Humidity: 90% non-condensing at 30 °C (MIL-STD-810F)</li> </ul>             |
|                                     | Mechanical   | <ul style="list-style-type: none"> <li>Vibration: Surface Ship, Marine Vehicles, Aircraft, Min. Integrity (MIL-STD-810F)</li> <li>Shock: 40 G, 11 ms (MIL-STD-810F)</li> </ul> |
|                                     | EMC  | MIL-STD-461E, CE Marking -Directives 73/23/EEC and 89/336/EEC  |
|                                     | MTBF   | > 40,000 hours   |
| <b>INSTALLATION</b>                 | Compact design: The unit occupies a width less than ½ of an 1U 19" rack slot               |  |
| <b>POWER CONSUMPTION</b>            | Operational < 10 Watt (Apparent power)   |  |
| <b>PRESETS</b>                      | Factory and Custom Presets   |  |

| INTERFACES   |  |
|--|--|
| <b>DCE (DATA) PORT (DB25M)</b>                       | RS-422 balanced, RS-423, RS-232 unbal., MIL-STD-188-114 (interoperable), EIA 530A compliant. Half & Full Duplex operation, Sync, Std. and High-speed Async modes. Connects to COMSEC.      |
| <b>ETHERNET DATA PORT (RJ45)</b>                     | IP Packet Data: 10/100 Base T (IEEE 802.3U compatible), embedded TCP/IP Stack<br>Protocol: RAW SIS IP packet data. Connects to application PCs / servers / laptops.                        |
| <b>REMOTE CONTROL/ GPS PORT (DE9M)</b>               | Remote Control Pins: RS-485 Multi-drop, RS-422 balanced or RS-232<br>Protocol: Control Protocol (RAP1 + RIPC, ASCII S5066 Annex E). Connects to RM8 SDM                                    |
|  | External GPS Control Pins: RS-232 (nominally input). Data Rate: 300 to 19200 bps. PPS line: RS 232/422 (NMEA) or TTL. Time reference, [position function]. Connects to external GPS.       |
| <b>GPS ANTENNA (MCX)</b>                             | Optional Built-in GPS receiver: Time reference for time-based functions, [position function].  |
| <b>SERIAL DATA (2) &amp; AUDIO PORTS (2) (DB25M)</b> | Asynchronous Data (2 ports): RS-232, up to 115200 bps, 1/2 stop bits, 5/6/7/8 bit data<br>Support for: ITA-2, ITA-5 for ACP-127 support. Connects to ACP 127 terminal.                     |
|  | Input Audio: 600 ohm balanced, -20 to +10 dBm without adjustment or MIC input Output Audio: Balanced, -40 to +10 dBm adjustable into 600 ohm load. Connects to intercom or hand / headset. |
| <b>ETHERNET CTRL PORT (RJ45)</b>                     | Remote Control: 10/100 Base T (IEEE 802.3U compatible), embedded TCP/IP Stack<br>Protocol: Control Protocol (RAP1 + RIPC). Connects to external management / control system.               |
| <b>USER INTERFACE FOR UNIT CONTROL</b>               | Local control via 32x202 pixel graphical LCD display and 16-key keypad. 3 bi-colour LED indicators<br>Alphanumeric and digit keypad for fast data entry, 4-way navigation button.          |
| <b>POWER SUPPLY</b>                                  | Wide-range supply input: 90-264 VAC, 40-440 Hz, 2A & 100-370 VAC.<br>Makes the unit suitable for use on military base stations, vessels and aircraft.                                      |

| ORDERING INFORMATION                  | STOCK NUMBER    | DESCRIPTION                     |
|---------------------------------------|-----------------|---------------------------------|
| RC8 ARQ SERVER & IP CONTROLLER        | RME-8C-P1-C11.0 | SDC: RC8 S5066 ARQ & IPC V1.0   |
| RC8X4 QUAD ARQ SERVER & IP CONTROLLER | RME-8C4P1-C11.0 | SDC: RC8X4 S5066 ARQ & IPC V1.0 |

\* Contact RapidM for datasheets.

Distributed by:

Rapid Mobile Pty (Ltd)  
Tel: +27 12 349 0000  
Fax: +27 12 349 0010  
Email: info@rapidm.com  
Web: www.rapidm.com

Apex Corporate Park  
Quintin Brand Street  
Persequor Park  
Pretoria, South Africa  
0020



Copyright © 2017 Rapid Mobile (Pty) Ltd  
Revision: RC8\_ARQ\_EN\_02A